

Order Confirmation OC-2205111-REV1

DYNAMICA SPRINT-KAPPA-SAMPLE

(1 DYS-3SSTT)
HT Rope Dyeing Machine



Dynamica Sprint



Dynamica Kappa



Dynamica Sample

The image shown in the picture is only an example of the product and may not represent the exact model offered.

PRODUCT PRESENTATION

Dynamicam Sprint is an ACIMIT Green Label-certified product.

What is Green Label ACIMIT ? It is a document aimed at identifying the energy and environmental performance of textile machines and making it easily understandable, with reference to a process chosen by the manufacturer as a benchmark.

Therefore, owing to the lack of internationally recognized standards for the classification of energy and/or environmental performance of textile machinery, Italian manufacturers, have turned into promoters of a tool whose purpose is to show some performance data of the machinery made.

Dynamica Sprint is ideal to dye fabrics in rope-form either open or tubular, both at low and high temperature values (144°C).

It is a vertical machine, suitable for dyeing of knits and woven(double-triple rope dyeing), even of heavy weight.

Owing to the possibility of treating fabrics with high transport speeds, at high temperatures, Dynamica Sprint is a machine particularly suitable for the preparation, dyeing and washing of fabrics in rope-form solving a variety of problems related with dyeing. (E.g. crease marks, meter to meter shade variation) .

The machine body contains one or more troughs which has the nominal capacity ranges are:

7 - 10 kg (Dynamica Sample); 25 - 100 kg (Dynamica Kappa);180 - 2.400 kg (Dynamica Sprint)) as a function of the weight of the articles being processed.

With fabric weights of about 250 g/linear metre or above, the nominal and actual loading capacities are equivalent.

The liquor ratio of the machine varies as a function of the characteristics of the fabric: with good approximation M:L=1,5+can be considered an absorption factor of the fabric (Knits-Upholstery models) ; M:L=1,5 + absorption factor (Towel models). M:L=3,5 + absorption factor (Sample models).

In Dynamica Sprint these M:L ratios are guaranteed thanks to the MCS patented **MULTISUCTION PUMP** and nominal loading capacity using a special plaiter which deposits the fabric along the whole width of the trough.

Machine performance optimized in addition with the self-cleaning static filter, **machine quick drain (MQD)** by main circulation pump, wall washing system, chemical dosing into the bottom of the vessel(in between multisuction point), variable nozzle(hydrovario), two chemical tanks and one machine **stock tank (MST)** for preparation of water (cold/hot) for successive machine fillings.

All parts of the machine that come into the contact with the fabric are manufactured using stainless steel type AISI 316/AISI 316 L. Also the cable trays along with the electrical cabinet made of stainless steel.

Dynamica Sprint is completely engineered, manufactured and tested in Italy.

THE HISTORY OF MCS ROPE DYEING MACHINES

- 1967 ITMA - Paris: MCS exhibits: the first low temperature jet model.
- 1979 ITMA - Hannover: MCS exhibits JET-HT and OVERFLOW MO / 80 LT
- 1983 ITMA - Milan: MCS exhibits SOFTFLOW 82 HT and FLO-JET OF83 HT
- 1987 ITMA - Paris: MCS exhibits PANDORA HT
- 1995 ITMA - Milan: MCS exhibits: SOFTFLOW 100 HT, LONG HORN HT.
- 1999 ITMA - Paris: MCS exhibits: MULTIFLOW HT, SOFTFLOW 100 SUPERIOR HT
- 2003 ITMA - Birmingham: MCS exhibits: MULTIFLOW SUPERIOR.
- 2007 ITMA - Monaco: MCS exhibits FIRST HT
- 2011 ITMA - Barcelona: MCS exhibits DYNAMICA HT
- 2015 ITMA - Milan: MCS exhibits DYNAMICA SPRINT HT
- 2019 ITMA - Barcelona: MCS presents SOFTFLOW 18 HT, exhibits DYNAMICA SPRINT HT

LAYOUT

STANDARD

N°	Model	Version	Loading (*)	Unit Price	Total Price
1	Dynamica Sprint	DYS-3SSTT	1.200 Kg		
1	Optional	DYS-3SSTT HT-DRAIN	/		

Total Supply				
--------------	--	--	--	--

SALES CONDITIONS

- **SHIPMENT**
180 Days from the date of completion of the TT payment (30.000€) (excluded 2 weeks Aug. - Dec.)
- **TRANSPORT**
CFR: Cost And Freight
- **PACKAGING**
Included
- **MOUNTING & COMMISSIONING**
Including the days of travel and work of the MCS technicians for mechanical assembly and electrical commissioning.
- **TRAINING**
Including the days of travel and 5 days of work of the technical specialists MCS for the training on-site.
- **SERVICES COSTS**
At customer's charge airtickets local transportation working lunch hotel and meals pocket money Euro 25 day. If necessary Covid quarantine board and Lodging costs of the period will be at Buyer charge
- **WARRANTY**
12 months after start-up, but no later than 15 months from date of shipment
- **TERMS OF PAYMENT**
 - 30.000 € TT payment in advance;
 - 175.000 € by Irrevocable and Confirmed LC payable at sight. The opening of the LC must be carried out no later than 150 days from the date of the total amount received in advance of 30.000 € (TT payment).
- **OUR BANK FOR YOUR PAYMENT**
CREDITO EMILIANO
SWIFT: BACRIT22XXX
IBAN: IT34 B030 3211 1000 1000 0000 959

MOUNTING AND COMMISSIONING

1. Parts excluded from MCS supply:

- All the material necessary for the realisation of foundations and bases
- All pipes for steam, air, water, chemical products, water drain condensate drain from Customer's supply lines to the usage point on the continuous range
- The Customer has to provide following utilities to the continuous range: filtered steam at 6 Bar; dehumidified compressed air at 6 Bar, filtered water at 2-3 Bar
- Reduction valves and safety valve for steam
- Tanks for the storage of chemical products
- Fabric necessary for testing the machine during the start-up
- All material not clearly specified in our offer.

2. The following personnel is required for machine commissioning:

- a) One qualified assembler for 3 days
- b) One electrician for 3-5 days
- c) One technologist for 3-5 days

3. Customer's assistance during erection and commissioning

The customer should make available at least one qualified mechanic of the maintenance service as well as one unskilled worker to assist our personnel.

Moreover, if necessary, the customer should provide for suitable assembly fixtures.

4. Requested interventions of our personnel

The customer should inform MCS at least one week in advance about a required intervention of MCS personnel for erection and commissioning. The respective communication has to be made through our agent. The date will be fixed by mutual agreement.

OUR PROPOSAL INCLUDES

Dynamica Sprint DYS-3SSTT

Maximum Loading: 1200 Kg

HT ROPE DYEING MACHINE

- Multi-Suction-pump at variable speed (MCS Patent)
- Fully automatic regulation with PCTE15 touch screen by Termolettronica (if not specified other operator panels)
- Preparation tank model MST .
- Two (2) add tanks with coil mixers, and probes.
- New Product Introduction System
- Seam detector and circulation control
- Continuous level control
- Liter counter for machine filling by volume
- New system for wall-rinsing
- SSCF System of principal filter on delivery pump self-cleaning
- Re-flux and dissolving feature for salt
- Quick drain feature , model MQD.
- Internal plaiters (one of each chamber) for fabric deposit into the processing trough
- Hydroflow : MCS variable nozzle dn 273 mm
- Transport tube dn 273 mm
- -Electrical cabinet completely in stainless steel with air-conditioner
- Set of Standard Valves
- 3 filling valves
- 2 drain valves
- Set of spare parts standard
- 1 sound alarm
- 1 kit of pre-wired stainless steel cable tray
- 1 full machine wiring cable kit

Optional DYS-3SSTT HT-DRAIN

H.T. DRAIN SYSTEM

- N°1 safety system for the control of the opening of machine breather valve (HT machine)
- N° 1 ON-OFF pneumatic valve for machine breathering for air inlet compensation during liquor drain.
- N°1 vacuum-breaker valve.
- N°1 ON-OFF pneumatic drain valve, selectable via PC

TECHNICAL FEATURES

DYNAMICA SPRINT	DYS-1	DYS-2	DYS-3	DYS-4	DYS-6
Min. Liquor Ratio	1.5 + FA*	1.5 + FA*	1.5 + FA*	1.5 + FA*	1.5 + FA*
Max. Temperature	144 °C	144 °C	144 °C	144 °C	144 °C
Max. Working speed**	400 m/min	400 m/min	400 m/min	400 m/min	400 m/min
INSTALLED POWERS***					
Main Pump	7,5 kw	15 kw	22 kw	2x15 kw	2x22 kw
Injection Pump	1,5 kw	1,5 kw	1,5 kw	1,5 kw	1,5 kw
MST Pump	1,5 kw	2,2 kw	2,2 kw	2,2 kw	4 kw
Unloading Reel	0,55 kw	0,75 kw	0,75 kw	2x0,75 kw	2x0,75 kw
Internal Reel****	1,5 kw	2x1,5 kw	3x1,5 kw	4x1,5 kw	6x1,5 kw
Internal Plaiter	0,25 kw	0,25 kw	0,25 kw	2x0,25 kw	2x0,25 kw
Add Tanks	2x0,37 kw	2x0,37 kw	2x0,37 kw	2x0,37 kw	2x0,37 kw
Total Installed Power	13,5 kw	23,5 kw	32 kw	42,5 kw	61,2 kw
MACHINE DIMENSIONS					
Width (A)	3.000 mm	4.300 mm	4.900 mm	5.900 mm	8.100 mm
Length without external reel (B)	4.000 mm	4.000 mm	4.000 mm	4.000 mm	4.000 mm
Length with external reel (C)	4.800 mm	4.800 mm	5.650 mm	5.650 mm	5.650 mm
Height (H)	3.500 mm	3.500 mm	3.800 mm	3.800 mm	3.800 mm

* FA: Fabric Absortion; **Max Reel speed of T-TT version: 200 m/min & U: 300 m/min; ** In case of installation over 1000 s.l.m. altitude above sea level, motor electric power will be increased of about 30%; **Internal reel: T-TT & U version: 2.2 kw;

The data in the table are not binding and they may undergo variations in order to improve the performance of the plant.
For more specific requests, MCS is available to send more detailed layouts and tables.

The following page shows the machine with RIGHT execution.
In the case of a LEFT machine the drawings are mirrored, with the same overall dimensions.

Loading capacity:

In case of DYNAMICA SPRINT for KNITTED OR WOVEN , we consider 100% CO FABRIC - weight aprox. 250 g/.l.m and over.
In case of DYNAMICA SPRINT for TERRY TOWEL FABRIC , we consider 100% CO FABRIC and weight aprox. 1.200 g/.l.m and over.

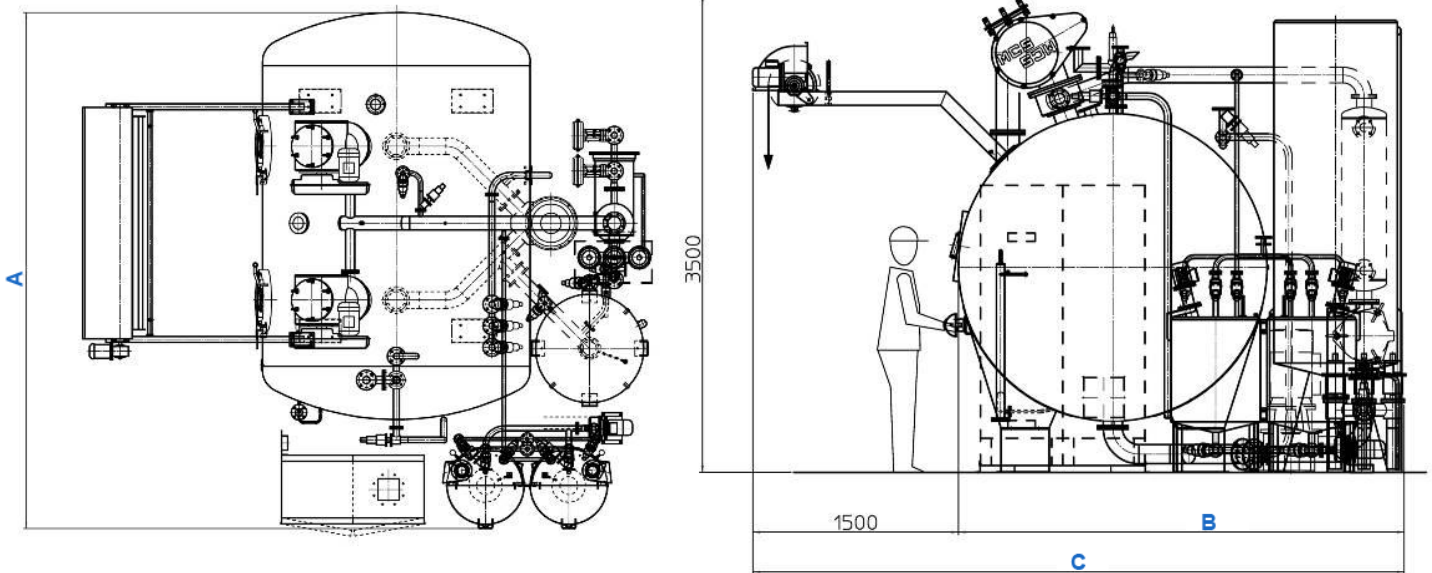

DYNAMICA KAPPA	DYS-K25	DYS-K50	DYS-K80	DYS-K100
Min. Liquor Ratio	3.5 + FA*	3.5 + FA*	3.5 + FA*	3.5 + FA*
Max. Temperature	144 °C	144 °C	144 °C	144 °C
Max. Working speed**	400 m/min	400 m/min	400 m/min	400 m/min
INSTALLED POWERS***				
Main Pump	5,5 kw	5,5 kw	5,5 kw	5,5 kw
Injection Pump	1,5 kw	1,5 kw	1,5 kw	1,5 kw
MST Pump (optional)	1,5 kw	1,5 kw	1,5 kw	1,5 kw
Unloading Reel	0,37 kw	0,37 kw	0,37 kw	0,37 kw
Internal Reel****	1,5 kw	1,5 kw	1,5 kw	1,5 kw
Add Tanks	2x0,37 kw	2x0,37 kw	2x0,37 kw	2x0,37 kw
Total Installed Power	11,10 kw	11,10 kw	11,10 kw	11,10 kw
MACHINE DIMENSIONS				
Width (A)	2.380 mm	2.380 mm	2.570 mm	2.570 mm
Lenght without external reel (B)	2.030 mm	2.030 mm	2.600 mm	2.600 mm
Lenght with external reel (C)	3.180 mm	3.180 mm	3.750 mm	3.750 mm
Height (H)	3.300 mm	3.300 mm	3.950 mm	3.950 mm

* FA: Fabric Absortion; **Max Reel speed of T-TT version: 200 m/min & U: 300 m/min; ** In case of installation over 1000 m. altitude above sea level, motor electric power will be increased of about 30%; **Internal reel: T-TT & U version: 2.2 kw;

The data in the table are not binding and they may undergo variations in order to improve the performance of the plant. For more specific requests, MCS is available to send more detailed layouts and tables.

The following page shows the machine with RIGHT execution. In the case of a LEFT machine the drawings are mirrored, with the same overall dimensions.

Loading capacity:

In case of DYNAMICA KAPPA and DYNAMICA SAMPLE for KNITTED OR WOVEN , we consider 100% CO FABRIC - weight aprox. 250 g/.l.m and over. In case of DYNAMICA KAPPA and DYNAMICA SAMPLE for TERRY TOWEL FABRIC we consider 100% CO FABRIC and weight aprox. 1.200 g/.l.m and over.

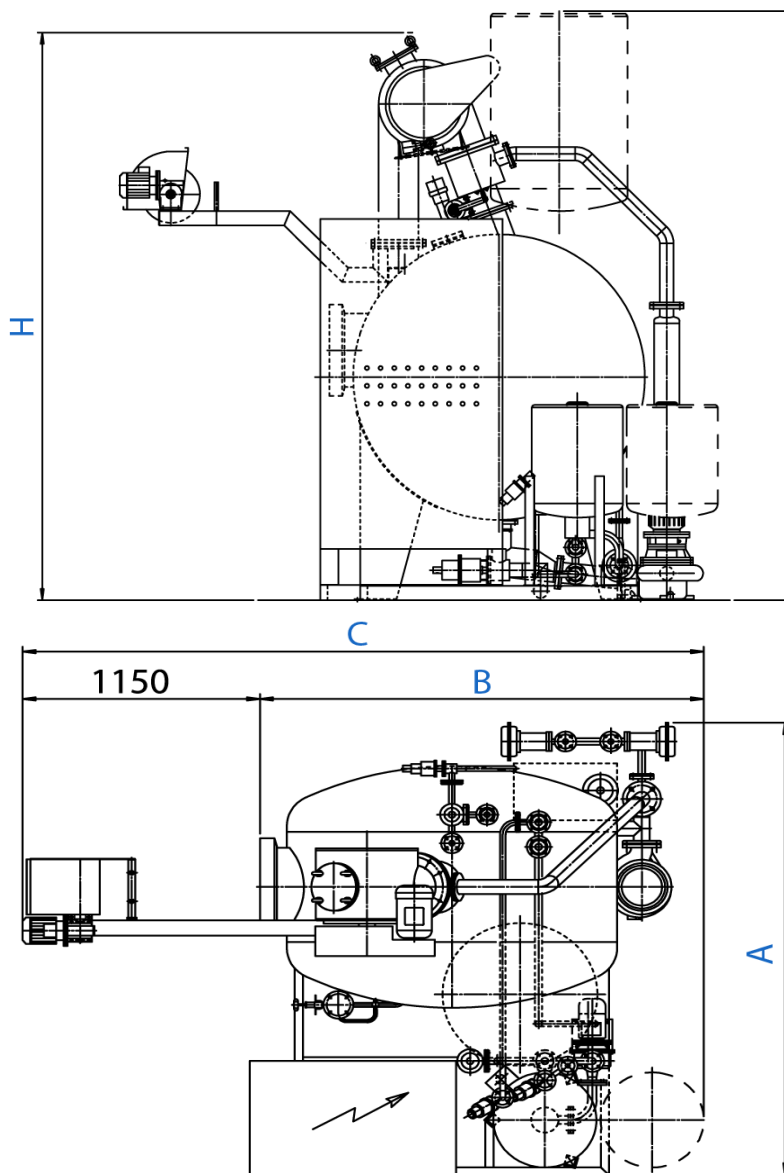

DYNAMICA SAMPLE	DYS-S10	DYS-S7
Min. Liquor Ratio	3.5 + FA*	3.5 + FA*
Max. Temperature	144 °C	144 °C
Max. Working speed	40 m/min	40 m/min
INSTALLED POWERS**		
Main Pump	3 kw	3 kw
Injection Pump	0,55 kw	0,55 kw
Internal Reel	0,37 kw	0,37 kw
Total Installed Power	4 kw	4 kw
MACHINE DIMENSIONS		

Width (A)	2.130 mm	2.130 mm
Lenght without external reel (B)	1.970 mm	1.055 mm
Height (H)	2.250 mm	1850

DYS-S10

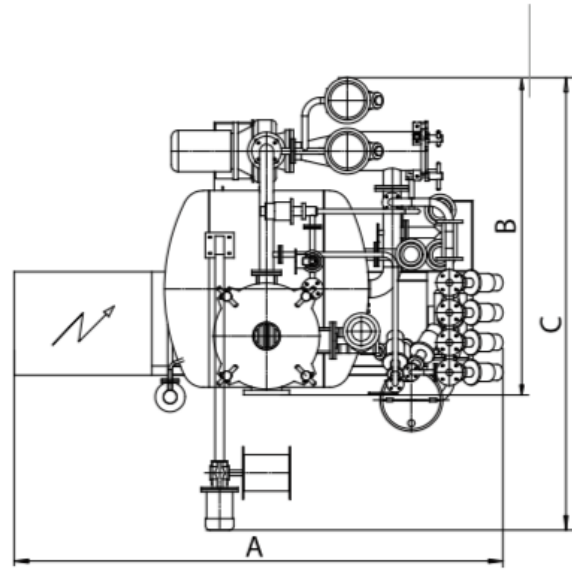
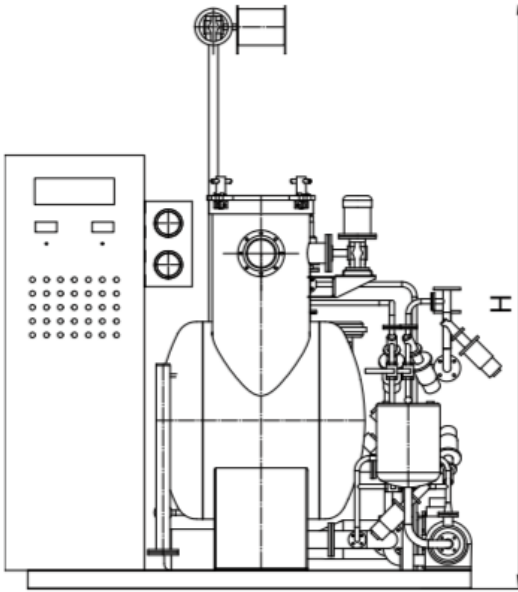

DYS-S7

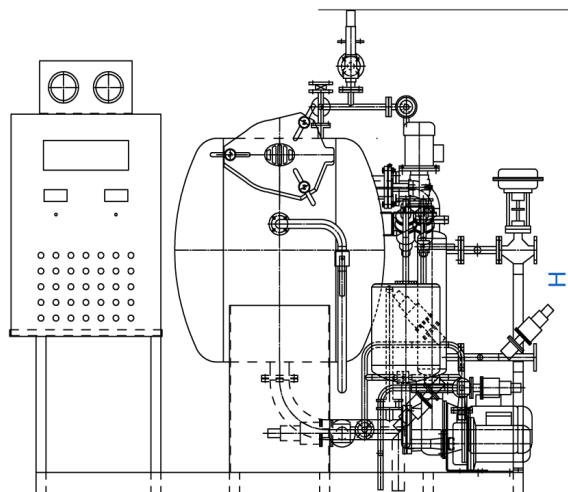
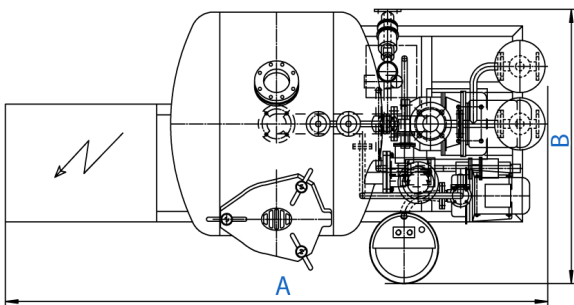

DYEHOUSE WATER SPECIFICATIONS

The following water specifications must be provided with below values in order to assure proper process quality and prevent machine damages.

MCS will not accept any responsibility in the event of any problem to process quality and/or machine damages caused by water quality not in compliance with the below values.

REQUESTED VALUE		
Manganese	0,02	mg/l
Iron (Fe)	0,1	mg/l
Nitrate (NO ₃)	50	mg/l
Nitrite	5	mg/l
Methyl orange alkalinity (CaCO ₃)	60	mg/l
Silicon Dioxide (SiO ₂)	3	mg/l
Filterable solids	50	mg/l
Water hardness	5°	dH (*)
Organic substance	20	mg/l
Colour	colourless	
pH	neutral (7 - 8)	
Salinity / TDS	150	mg/l
Smell	odorless	
Suspended solid	1	mg/l
Solid residues from evaporation	500	mg/l
Copper (Cu)	0,005	mg/l

(*) 6, 25 o eH ; 8 , 95o fH; 5,2 USA

NOTE: mg/l = ppm

MCS OFFICINA MECCANICA S.P.A.

Technical department

WHO WE ARE

MCS s.p.a. leads a mechano-textile group (www.mcsgroup.it) that started operating in the early sixties thanks to Gino Chiappini and Angelo Cagnazzo, Italo Pilenga.

The group includes TERMOELETTRONICA (industrial automation plants and monitoring/control systems) and EUROPIZZI (sub-contracted dyeing-finishing works and manufacturer of chemical auxiliaries).

MCS products have always been extensively tested in the group's dyehouse before being launched on the market.

We are waiting for you to proudly show you our reality!



MCStextile.it

- High and low-temperature rope-dyeing machines and open-width dyeing machines.
- Open-width and rope bleaching lines for knits and wovens, open-width and rope washing lines for knits and wovens.

Termoelettronica.it

- Automatic and semi-automatic dosing systems for liquid auxiliary chemicals, powders dyestuff and salt.
- Management software solutions for textile automation and operators panels.

Europizzi.it

- 100% outsourced dyeing-finishing, auxiliary chemicals for textile and non-textile industry and renewable energy manufacturer

GENERAL SALES CONDITIONS

1) **CONTRACT** – The order is considered valid only upon receipt of confirmation of order, duly signed for acceptance by the Purchaser. Any modification that the Purchaser should later wish to make will not be considered valid unless accepted in writing by the Seller, eventually specifying new delivery terms and prices.

2) **PLANS AND DRAWINGS** – Sizes, illustrations, drawings, etc. are not binding. For weight a tolerance of $\pm 5\%$ is allowed according to the type of equipment to be supplied with the plant and/or machinery. Any technical drawing or document enabling the manufacture, processing or assembling of the products sold or of parts of them given to the Purchaser, whether before or after entering the contract, shall remain exclusive property of the seller. The drawing or documents here above shall be used by the Purchaser nor copied, reproduced or transmitted to third parties without the Seller's consent.

For electrical equipment, reference should be made to the supply conditions as settled by the electro-mechanics and electronic industries.

The Seller is freed from any responsibility due to possible delays in delivery or regarding the quality of the materials, if the supply of the latter, was imposed by the Purchaser.

3) **PRICES AND PAYMENT TERMS** – The reference that may be made to commercial terms (ex-works, FOB, CIF, etc.) is understood to be made to the Incoterms of the International Chamber of Commerce in the text in force at the moment of entering the contract. Payment is always to be considered as net cash at the Seller's address and is to be done according to the terms settled in the contract. As a rule, the payment form considers a down payment of at least 30% of the total value of the goods supplied. Missing of accessory equipment that does not prevent normal use of the plant and/or machinery is not a valid reason for partial or total suspension of payment. Modifications or additional equipment required by the Purchaser carried out on the plant and/or the machinery already ordered must be paid for when settlement is made. If forwarding of the goods is delayed on Purchaser's request or by Purchaser's default, the latter must pay all the related expenses.

4) **RESERVATION OF PROPRIETARY RIGHTS** – The plant and/or the machinery will remain the Seller's property until all of its claims resulting from the contract have been paid in full. The Purchaser cannot resell or give as a guarantee the purchased plant and/or machinery without first having paid the full price of it to the Seller, who must be notified immediately by registered letter of the procedures actuated by third parties against the plant and/or the machinery. Violation of the terms settled by the present item gives the Seller the right to terminate the contract. In this case the Seller must inform the Purchaser that he wishes to enforce the clause that allows termination. The Seller will then have the right to ask for damages for all the expenses resulting from the contract termination. After the delivery of the goods, all risks will be on Purchaser's account. It is understood that expense resulting from authorised drafts and/or renewed drafts, if not paid on maturity, do not affect the agreement as to the place of payment, which must in fact be at the Seller's address.

5) **DELIVERY** – If not otherwise agreed upon, delivery of the goods is intended ex-works. The delivery date, which is to be considered indicative, is to be calculated from the date of payment of the percentage as stated in paragraph 3 to the date of advice that the goods are ready to be shipped. Observance of the delivery terms agreed upon presumes the observance of all the obligations stated in the contract by the Purchaser. The delivery date may be postponed due to circumstances beyond the Seller's control, such as strikes, fires, floods, lack of motive power, delay in receiving materials from sub-manufacturers etc. It may also be post-poned if there are delays in obtaining permission from the Authorities, lack of documents or information necessary for the execution of the order, or following modifications requested at a later date by the Purchaser. The Seller has the right to cancel the contract either in part or in full if the indicated causes beyond his control prevent or delay execution of the contract and/or the delivery of the plant and/or machinery, without the Purchaser being entitled to claim compensation or allowances of any kind. If, due to the fault of the Seller, there is a delay in delivery, the Purchaser, after having proved that he has been damaged, may, for such damage, request as compensation under tacit agreement that no further claim is made, an allowance of a maximum of 0.25% of the value of the part of the consignment that has been delayed and for each week of delay, with an exemption the first 30 working days. Said penalty must not, however, exceed 5% of the value of the non-delivered part (referring only to plant and/or machinery, accessories and equipment excluded). All other responsibilities or allowances by the Seller to the Purchaser as direct or indirect consequences of the delay are excluded. The possibility for the Purchaser to cancel the order for such delay is also excluded.

6) **PACKING** – If the Purchaser does not expressly state otherwise, the Seller will provide packing at his own discretion, and such packing is to be considered a state-of-art execution if accepted without questioning by the carrier.

7) **TRANSPORTATION** – The goods always travel on account of the Purchaser, at his own risk, even if delivery free at the Purchaser's address is agreed upon. The Purchaser may duly check the goods before acceptance and express his own reservation. If carriage of goods is partially or totally delayed due to the Purchaser's fault, all risks and/or responsibilities for the conservation of the plant and/or machinery, change from the Seller to the Purchaser as from the date of advice that the goods are ready for shipment, irrespective of the fact that the Seller may or may not have right of ownership. The Seller may also claim storage charges.

8) **TESTING** – Before delivery is done, testing of the plant and/or machinery to be delivered will take place at the Seller's factory. Testing must also be carried out according to the techniques and procedures settled for that type of plants and/or machinery, as per conditions agreed upon in writing, between the two interested parties. If the Purchaser should wish to be present during testing, he must request in advance to be advised. A functional testing may be carried out when the plant and/or machinery has been installed, if expressly requested by the Purchaser, by the Seller's specialised staff. The Purchaser, in this case, must pay testing expenses.

9) **GUARANTEE** – The Seller guarantees the plant and/or machinery for 12 months as from date of start-up and however, not more than 15 months from the date of shipment. More than 48 working hours per week will reduce, proportionally the period of guarantee. For certain articles, expressly stated in the contract, a different period of guarantee from the one stated in the previous paragraph may be established.

The guarantee covers all manufacturing and working faults and faulty materials, the latter only when it can be ascertained as such by testing methods and equipment at Seller's disposal. Deficiencies and faults due to normal wear and tear are not covered by the guarantee.

The Purchaser has the right, at Seller's discretion, to have those parts which are proved to be faulty, either substituted or repaired, all other forms of guarantee are excluded. In particular, compensation for direct or indirect damage caused to people, things, production, even if it is due to bad operation of the equipment and/or machinery installed on the Seller's plant and /or machinery, or due to faulty materials or construction, is excluded.

The Purchaser must advise Seller of any fault as soon as it is found, and on request, send to the Seller's factory those parts which are to be substituted or repaired free of charge. The Purchaser must allow the Seller the necessary time to substitute or repair such parts, as well as provide to collect the new or repaired

parts. If the parts are to be repaired or substituted at the Purchaser's address, the latter must supply the necessary auxiliary labour. If the claim proves to be unwarranted the expenses of substitution and/or repair will be charged to the Purchaser. The guarantee excludes faults deriving from causes beyond control, bad installation (if this is not carried out by the Seller), carelessness or unskilfulness of the operator, overload and other causes of this kind.

The guarantee ceases to be valid if the Purchaser has modified the plant and/or machinery or part of it without the Seller's written permission. Obligation deriving from guarantee does not authorize suspension of payment, which anyhow, must be done at maturity and at the conditions agreed upon. If the Purchaser has not duly made all payments, he cannot ask Seller to fulfil the obligations of the guarantee.

10) DISPUTES – The disputes, according to the contract, must always be discussed at the Seller's address. Any dispute regarding enforcement and interpretation of the contract will be decided by 3 arbitrators who will act in a friendly manner, nominated as follows: one by the Seller, one by the Purchaser and one by A.C.I.M.I.T.

The respective expenses are to be paid by the defaulting party.

For any dispute the competent Court of Justice is the Court of Bergamo, also in case of payment against drafts.

11) VALIDITY – The order implies acceptances of the above general sales conditions, to which no exceptions can be made, unless expressly stated in writing. These contract regulations may be interpreted only according to Italian law and the Italian text of these regulations.

- The terms of sales should be interpreted according to "INCOTERMS 2000" regulations of the International Chamber of Commerce (ICC) in Paris – (brochure N. 560).

- Documentary credits should be interpreted according to "UNIFORM REGULATIONS AND USE OF DOCUMENTARY CREDITS 1993" of the International Chamber of Commerce (ICC) in Paris – (brochure N. 500).

12) SUPERVENING UNCONSCIONABILITY:

The inclusion in these General Terms and Conditions of Sale of the Hardship Clause is agreed by the Parties.

The Parties agree that, in accordance with the provisions of art. 1467 of the Italian Civil Code, the situation of excessive burdens occurred (hardship) can be recognized in the event of very serious circumstances, such as by way of example and not limited to: extreme currency devaluations, changes in exchange rates, change in the customs regime of contractual products, considerable increases in the cost of raw materials or in transport costs.

In these circumstances, the Seller reserves the right to increase the price agreed in the Contract by sending the proposal to the Buyer who has the right to withdraw from the contract by communicating it to the Seller by registered letter with return receipt within 15 (fifteen) days after receiving the notification of the price increase notice.

Failing this, the Buyer's will to accept the price increase will be understood as implicit.

For acceptance

(The buyer)